

Video Solution on Website:-

<https://physicsaholics.com/home/courseDetails/83>

Video Solution on YouTube:-

<https://youtu.be/tBekn2ld5eE>

Written Solution on Website:-

<https://physicsaholics.com/note/notesDetails/21>

Q 1. A uniformly tapering vessel of height  $h$  whose lower and upper radii are  $r$  and  $R$  ( $r < R$ ) is completely filled with a liquid of density  $\rho$ . The force that acts on the base of the vessel due of the liquid is

- (a)  $\pi R^2 \rho gh$                       (b)  $\pi r^2 \rho gh$   
 (c)  $\pi \left(\frac{R+r}{2}\right)^2 \rho gh$                       (d)  $\frac{1}{3}\pi(R^2 - r^2)\rho gh$

Q 2. A uniformly tapering vessel is filled with a liquid of density  $900\text{kg/m}^3$ . The force that acts on the base of the vessel due to the liquid is ( $g = 10\text{ m/s}^2$ )

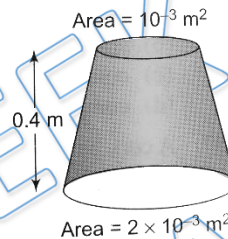

- (a) 3.6 N                      (b) 7.2 N  
 (c) 9.0 N                      (d) 14.4 N

Q 3. The height of a mercury barometer is 75 cm at sea level and 50 cm at the top of a hill. Ratio of density of mercury to that of air is  $10^4$ . The height of the hill is

- (a) 250 m                      (b) 2.5 km  
 (c) 1.25 km                      (d) 750 m

Q 4. Equal masses of water (density is 1) and a liquid of density 2 are mixed together, then the mixture has a density of

- (a)  $\frac{2}{3}$                       (b)  $\frac{4}{3}$   
 (c)  $\frac{3}{2}$                       (d) 3

Q 5. A manometer is connected to gas container. Then the mercury level rises by 2 cm in the arm of the manometer which is not connected to the container. If the atmospheric pressure is 76 cm of mercury, then the pressure of the gas is \_\_\_\_\_ cm of mercury.

- (a) 80                      (b) 76  
 (c) 72                      (d) 78

Q 6. A barometer kept in a stationary elevator reads 76 cm. If the elevator starts accelerating up the reading will be

- (a) zero (b) equal to 76 cm  
(c) more than 76 cm (d) less than 76 cm

Q 7. If the container is accelerating along a direction as shown in figure. Find the angle  $\theta$  made by liquid surface as shown.

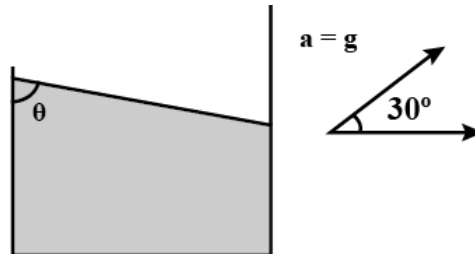

- (a)  $30^\circ$  (b)  $150^\circ$   
(c)  $60^\circ$  (d)  $120^\circ$

Q 8. A barometer kept in an elevator accelerating upwards reads 76 cm of Hg. If the elevator is accelerating upwards at  $4.9 \text{ m/s}^2$ , what will be the air pressure in the elevator?

- (a) 76 cm of Hg (b) 94 cm of Hg  
(c) 64 cm of Hg (d) 114 cm of Hg

Q 9. A closed tank filled water is mounted on a cart, The cart moves with an acceleration "a" on a plane road. What is the difference in pressure between points B and A shown in figure?

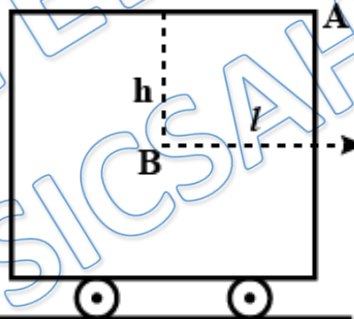

- (a)  $h\rho g$  (b)  $(h + l)\rho g$   
(c)  $(hg + al)\rho$  (d)  $(h - l)\rho g$

Q 10. In the given figure, the container slides down with acceleration 'a' on an incline of angle ' $\theta$ '. Liquid is stationary with respect to container. Find out angle made by surface of liquid with horizontal plane

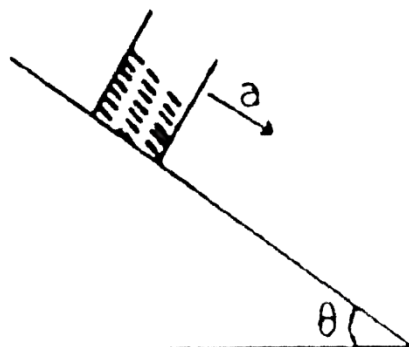



- (a)  $\tan^{-1} \left[ \frac{a \cos \theta}{g - a \sin \theta} \right]$   
 (b)  $\tan^{-1} \left[ \frac{a \cos \theta}{g + a \sin \theta} \right]$   
 (c)  $\tan^{-1} \left[ \frac{a \sin \theta}{g - a \cos \theta} \right]$   
 (d)  $\tan^{-1} \left[ \frac{a \sin \theta}{g + a \cos \theta} \right]$

Q 11. A cylinder of water, is rotating about its own axis with uniform angular velocity  $\omega$ .

The shape of free surface of water will be

- (a) parabola (b) elliptical  
 (c) circular (d) spherical

Q 12. A liquid is kept in a cylindrical jar, which is rotated about the cylindrical axis. The liquid rises at its sides. The radius of the jar is  $r$ , and speed of rotation is  $\omega$ . The difference in height at the center and the sides of the jar is:

- (a)  $\frac{r^2 \omega^2}{g}$  (b)  $\frac{r^2 \omega^2}{2g}$   
 (c)  $\frac{g}{r^2 \omega^2}$  (d)  $\frac{2g}{r^2 \omega^2}$

Q 13. A cylinder of radius  $R = 1$  m and height  $H = 3$  m two-third filled with water is rotated about its vertical axis as shown in figure. Determine the speed of rotation when the point at the center of the base is just exposed

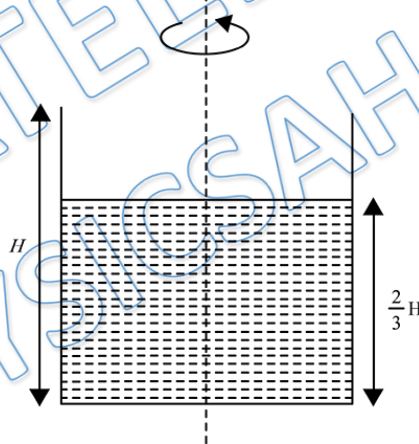

- (a)  $\sqrt{30}$  rad/s (b)  $\sqrt{20}$  rad/s  
 (c)  $\sqrt{60}$  rad/s (d)  $\sqrt{50}$  rad/s

Q 14. On a smooth inclined plane making an angle  $\theta$  with horizontal a trolley containing a liquid of density  $\rho$  slides down. The angle of inclination  $\phi$  of free surface of liquid with horizontal is:

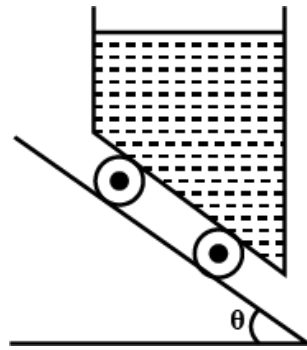

(a)  $\phi = \theta$

(c)  $\phi = \frac{\theta}{9}$

(b)  $\phi = \frac{\theta}{3}$

(d)  $\phi = \frac{2\theta}{3}$

PRATEEK JAIN  
PHYSICSAHOLICS

## Answer Key

<b>Q.1 b</b>	<b>Q.2 b</b>	<b>Q.3 b</b>	<b>Q.4 b</b>	<b>Q.5 a</b>
<b>Q.6 d</b>	<b>Q.7 c</b>	<b>Q.8 d</b>	<b>Q.9 c</b>	<b>Q.10 a</b>
<b>Q.11 a</b>	<b>Q.12 b</b>	<b>Q.13 c</b>	<b>Q.14 a</b>	